

# JVC<sup>®</sup>

The Perfect Experience / —

## DLA-RS2

1080p High Definition Home Theater Front Projector



### D-ILA<sup>®</sup>

REFERENCE SERIES



## Visual Perfection

Realism Unlike Anything You've Seen with the Deepest Blacks and Most Vibrant Natural Colors

The new DLA-RS2 brings a true theater experience to your home as it projects images more realistically and naturally than ever before possible. JVC's recent advancements in optics and chip technology enable the DLA-RS2 to produce an incredible 30,000:1 native contrast ratio, which when combined with legendary D-ILA color reproduction and enhanced gamma optimization, results in remarkable performance that rivals master film seen only in Hollywood screening rooms.

**D-ILA**<sup>®</sup>

*REFERENCE SERIES*



**D-ILA**

**Full HD**  
1920x1080

**HDMI**<sup>™</sup>  
x2 (v.1.3)



Show the contrast and colors,  
the way you like it.



## Breathtaking Colors and Contrast

### 30,000:1 native contrast ratio — the industry's highest\*1

The DLA-RS2 achieves the industry's highest native contrast ratio without artificial means such as a dynamic iris. JVC has improved its three 1920 x 1080 D-ILA devices to further reduce stray light and has upgraded its optical engine with an improved wire grid polarizer.

\*1 As of September 2007. Native contrast ratio of 30,000:1 for home theater projector class (JVC internal survey).

### Exclusive D-ILA technology

D-ILA is JVC's proprietary version of LCOS or Liquid Crystal on Silicon. Unlike competing single-chip DLP projectors, JVC utilizes three D-ILA chips to eliminate color dithering, color wheel, and rainbow effect, allowing the DLA-RS2 to produce the most natural color images of any projector at any price.

### Wider color gamut for a natural yet cinematic display of color

The DLA-RS2 incorporates a finely tuned color filter set that dramatically improves color rendition to make images come alive — especially those containing red such as skin tones and sunsets. Scenic views with blue skies and hot-air balloons are also vibrantly displayed as if you were actually there.

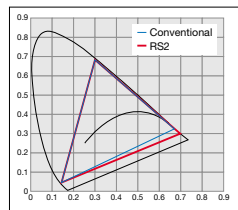
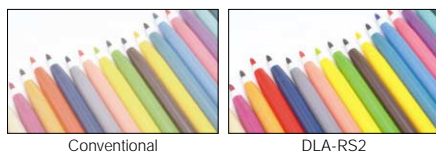

### Gennum VXP video processing

The GF9351 video processor from Gennum Corporation, which provides superior scaling capability, has been adopted for the video circuitry to ensure high-definition picture quality.

### Gamma optimization via on-screen control

As ambient lighting conditions will differ slightly with each application, the screen may require minor adjustments of gamma or gray scale. And the DLA-RS2 makes this easy by including an on-screen utility that optimizes the projector for a variety of viewing conditions or personal preferences. Red, green and blue levels can be adjusted independently or together as a group at several points along the gamma curve.

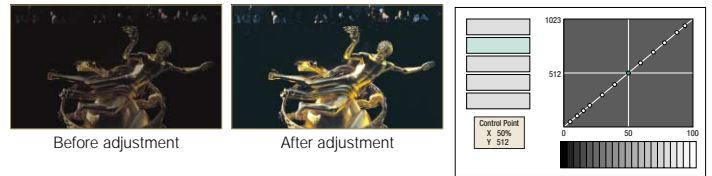

### HDMI ver. 1.3 (Deep Color) compatibility

Connectivity is extremely important in home theaters as a variety of input devices covering a wide range of entertainment choices are typically connected to the projector. And the DLA-RS2 answers this need as it features two HDMI inputs with version 1.3 (Deep Color) specification connectivity. Version 1.3 specifications allow you to take full advantage of the higher bandwidth of 225 MHz, increased color depth from millions of colors to billions of colors (Deep Color) as well as enhanced resolution and frame rates. As an added convenience, the connector spacing has been increased to accommodate professional-grade HDMI cables.



## User-friendly Convenience

### Full 2.35:1 wide cinematic movie enjoyment

On conventional projectors, 2.35:1 wide cinematic films are displayed letterboxed with black bars on the top and bottom of the screen. An optional anamorphic lens can be used that allows the projector to utilize the full picture area for the 2:35 image thanks to a V-stretch mode. Constant picture height is maintained for all aspect ratios, allowing 100% pixel resolution in both 1.78:1 and 2.35:1 modes.

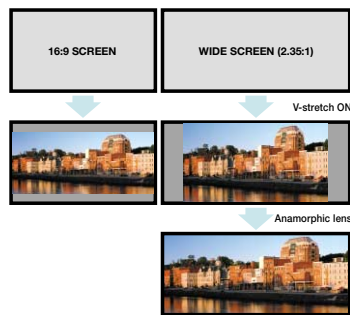

RSVP1  
Video Processor



RSAL1  
Anamorphic Lens

### Handy video adjustment menu

A convenient and detailed video adjustment menu allows you to easily adjust the picture to suit the source video and your own preferences.



### Air intake and exhaust vents on the front of the unit

Installing a projector on the ceiling was sometimes problematic because of the top cooling vents, but JVC has skillfully positioned both air intake and exhaust vents at the front of the unit to let you easily install the DLA-RS2 anywhere — on the ceiling, right up against a wall, or simply on top of a table. And the improved cooling design keeps fan noise down to about 24dB so that everyone can better enjoy what is being shown.



### Access panel for the replaceable lamp on the side

Another thoughtful design feature is the access panel for the replaceable lamp, which is located on the side of the projector to make replacement easy.



Access for lamp replacement

### Self-illuminating remote control

The buttons on the handy self-illuminating remote control light up automatically, making it easy to operate even in a dark room. The remote control also includes direct keys to adjust frequently used functions such as contrast and brightness, in addition to video input selection.



Superlative Technologies for Ultimate Picture Quality

**0.7-inch (16:9) full HD D-ILA device**

The heart of the 30,000:1 native contrast ratio is the D-ILA (Direct-drive Image Light Amplifier) imaging device that enables an extremely low black level to be projected. This incredible native contrast ratio is achieved via significant advances in the manufacturing process of the D-ILA device and continuous improvement in the overall optical engine design specific to the DLA-RS2. What's more, a D-ILA device-only contrast ratio of 40,000:1 has been made possible and the elimination of the need for any type of iris or shuttering system, which could detract from the frame-by-frame capabilities of the projector and decrease the dynamic range of a single frame, are just some of the advances JVC has to offer. This means, for example, that the DLA-RS2 can display a frame containing a star-lit nighttime scene combined with a bright foreground skyline at full dynamic range. Film content filled with shadow details in one part of the image and bright highlights in another would also be faithfully reproduced at full 30,000:1 contrast ratio in every frame.

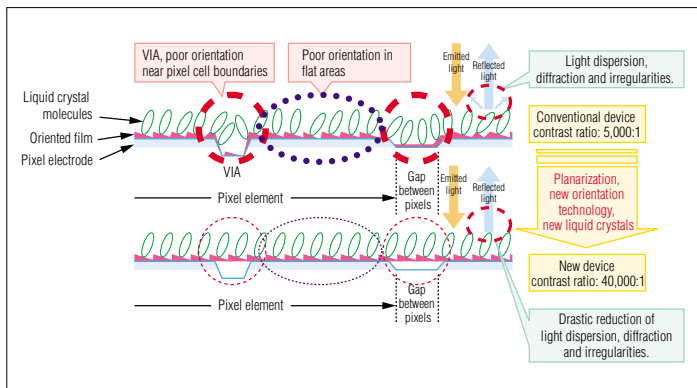
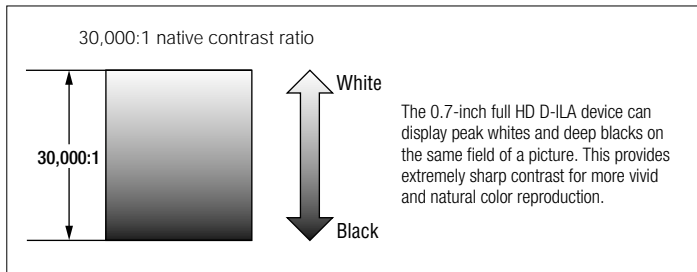

**Three D-ILA devices for a smooth, film-like picture**

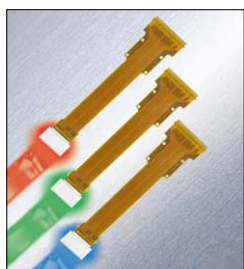

JVC D-ILA projectors employ three devices, for red, green and blue, to ensure a naturally rich, flicker-free picture without the kind of color degradation that can often occur with single-device projectors. The D-ILA device also has a fast response time and is especially suited for viewing rapid movement such as sporting events. Minimal pixel gap in the D-ILA reduces the amount of visible pixel structure in the projected image and the result is a smoother picture, like that of 35mm film, with fine details all the way to each edge of the screen.

35mm film, with fine details all the way to each edge of the screen.

**High-efficiency optical engine**

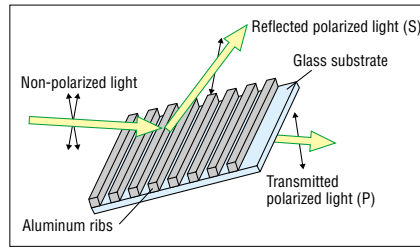

How the wire-grid polarizer works

Efficient polarization in the optical engine is critical to achieving an extremely high native contrast ratio. Inorganic wire grid polarizer plates used in the optical engine dramatically improve the precision of light polarization to help prevent stray light leak-

age into the internal optics and projection lens. The wire grid design employed by the JVC optical engine uses an inorganic reflective polarizing plate made from a glass substrate on the surface that has ultra-fine aluminum ribs. The combination of this polarizer with the newly developed 0.7-inch 1080p D-ILA vertically aligned liquid device enabled the DLA-RS2 to realize a 30,000:1 native contrast ratio.

The optical engine also ensures that all colors are vividly reproduced with smooth gradations and minimal noise together with a consistent response regardless of the content brightness level.

**High-performance 2x motorized zoom lens**



The high-performance 2x motorized zoom lens found on the DLA-RS2 is made by Fujinon Corporation and features a large-diameter, all-glass lens assembly with 16 elements in 13 groups. Motorized focus also allows you to enjoy razor-sharp image reproduction in every viewing situation even in smaller rooms as only a distance of 10 ft (at a projection distance of 10.1 to 20.3 ft) is required to properly display images at a

100-inch screen size. Best of all, the high-performance motor makes even tedious zoom and focus adjustments a breeze.

**Flexible set-up**

Setting up the DLA-RS2 is easy too as the  $\pm 80\%$  vertical and  $\pm 34\%$  horizontal lens shift function allows the projected picture to be moved horizontally or vertically without having to physically reposition the projector.

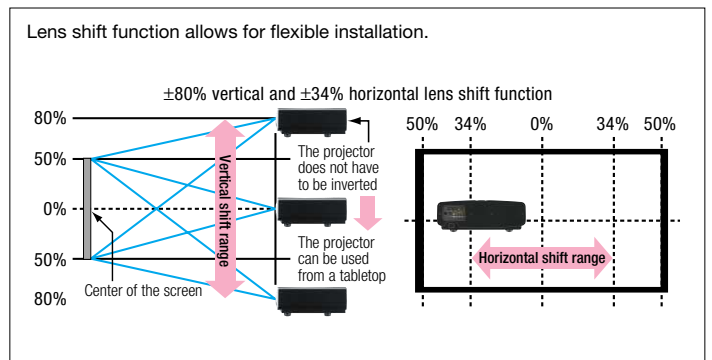

The vertical and horizontal lens shift function cannot be set to the maximum values simultaneously.

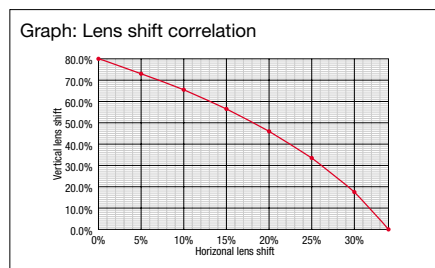

### Video Processor and Anamorphic Lens Accessories

Specific accessories for the JVC DLA-RS2 high-definition home cinema projectors are available including the RSVP1 video processor and the RSAL1 anamorphic lens solution. With JVC's video processor and anamorphic lens solution, you can convert your projection system to the true widescreen cinema aspect ratio of major motion pictures and eliminate the black bars. Experience the remarkable feel of the true widescreen format and watch movies in all their grandeur!



#### RSVP1 Video Processor

The RSVP1 video processor serves as your complete A/V hub, providing audio/video switching that allows a one wire connection to display all of your video needs.

- Multiple input source switching
- High-quality processing and scaling for anamorphic mode
- Single-command switching for anamorphic mode
- Edge adaptive processing for smooth diagonal edges
- Three frame video processing delay (Max)
- Game Mode with very low latency
- Sub-1 frame delay with edge adaptive processing
- AV Lip Sync



#### RSAL1 Anamorphic Lens

The RSAL1 is a high performance anamorphic add-on lens installed in front of digital projectors to convert them to a higher (wider) aspect ratio. The RSAL1 can be used for constant height 2.35:1 imaging as either a moveable lens (electronic vertical image stretch required for 2.35:1 content) or a fixed lens (both electronic vertical stretch and horizontal squeeze [for non-2.35:1 content] required).

- Black aluminum and molded plastic housing with included black aluminum bracket.
- Total lens weight with bracket of approximately 8.5 lbs (3.8 kg). Lens dimension without bracket is approximately 5.4" wide x 5" high x 7.6" long.
- Large entrance aperture of 3.1" x 3.1" (4.3" diagonal) for maximum versatility.
- Five element, 100% glass, patented, fully multicoated optical design corrected for chromatic aberration and astigmatism in standard home cinema environments.
- Accepts even large beams and produces low distortion and exceptional image quality up to and beyond 1080 resolution at throw ratios down to 1.6 (image distance divided by pre-lens image). Supports throw ratios down to 1.4 when used with smaller beams and curved projection screens.

### Specifications

Display device	1080p D-ILA device
Panel size	0.7 inch x 3 (16:9)
Resolution	1,920 x 1,080 pixels
Lens	2x motorized zoom/focus lens 1.4-2.8:1 * Screen Width f=21.3-42.6mm F=3.2-4.3
Projection size	60 inches to 200 inches
Lens shift lamp	±80% vertical and ±34% horizontal
Contrast ratio	Native : 30000:1 (Device 40000:1)
Input terminals (back panel)	HDMI x 2 (ver. 1.3) can also be used as PC input Component x 1 (3 RCA) can also be used as an RGB terminal. S Video terminal (mini DIN4 pin) x 1 Composite x 1 (1 RCA terminal)
Control terminals	RS-232 (D-sub, 9-pin)
Video input signals	480i/p, 576i/p, 720p 60/50, 1080i 60/50, 1080p 60/50/24, NTSC/NTSC4.43/PAL/PAL-M/PAL-N/SECAM
Noise level	24dB (in normal mode)
Power consumption	280 watts (2.7 watts in stand-by)
Dimensions (W x H x D)	17-29/32" x 6-51/64" x 16-15/32" (455 x 172.5 x 418.5mm) without extrusions
Weight	25.6 lbs. (11.6kg)

### Projection Distance Chart

Diagonal (Inch)	Display size (16:9)		Projection distance	
	W (mm)	H (mm)	Wide (m)	Tele (m)
60	1,328	747	1.78	3.63
70	1,549	872	2.09	4.24
80	1,771	996	2.40	4.86
90	1,992	1,121	2.71	5.47
100	2,214	1,245	3.01	6.08
110	2,435	1,370	3.32	6.70
120	2,656	1,494	3.63	7.31
130	2,878	1,619	3.93	7.93
140	3,099	1,743	4.24	8.54
150	3,320	1,868	4.55	9.16
160	3,542	1,992	4.86	9.77
170	3,763	2,117	5.16	10.38
180	3,984	2,241	5.47	11.00
190	4,206	2,366	5.78	11.61
200	4,427	2,490	6.08	12.23

\*Projection distances are design specifications, so there is ±5% variation.

### Rear terminals



### Optional Accessory



BHL5009-S

User-replaceable Lamp

### External dimensions Unit : inch (mm)

■ Top

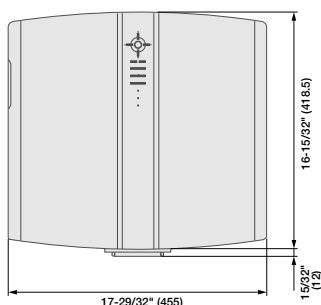

■ Front

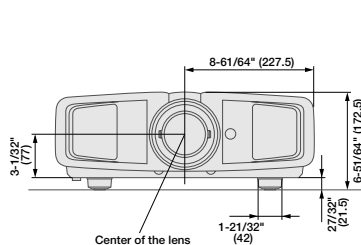

■ Bottom

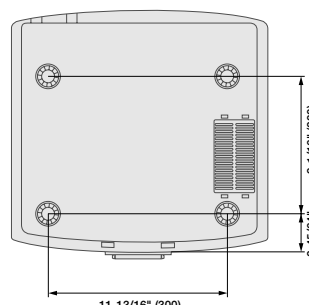

■ Side (left)

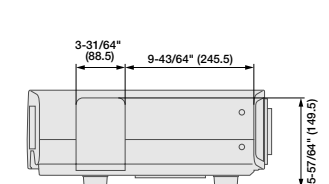

# REFERENCE SERIES

The projector is equipped with a high-pressure mercury lamp, which may break, emitting a loud noise, when it is subjected to shock or after it has been used for a prolonged length of time. Please note that, depending on how the projector is used, there will be considerable disparity between individual lamps on how long they will operate before replacement is required. The owner of the projector is responsible for all costs related to the replacement of the lamp. Design and specifications are subject to change without notice.

- The projector lamp requires periodic replacement and is not covered by warranty.
- Please note that, although the D-ILA device is manufactured using highly advanced technologies, 0.01% or fewer of the pixels may be non-performing.

All pictures on this brochure are simulated. Fujinon is a registered trademark of Fuji Photo Film Co., Ltd. VXP™, VISUAL EXCELLENCE PROCESSING™ and VXP logo are trademarks or registered trademarks of Gennum Corporation. HDMI, the HDMI logo and High-Definition Multimedia Interface are trademarks or registered trademarks of HDMI Licensing LLC. All other brand or product names may be trademarks and/or registered trademarks of their respective owners. Any rights not expressly granted herein are reserved.

Copyright © 2007, Victor Company of Japan, Limited (JVC). All Rights Reserved.

# JVC®

DISTRIBUTED BY

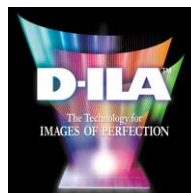

**JVC PROFESSIONAL PRODUCTS COMPANY**  
DIVISION OF JVC AMERICAS CORP.  
1700 Valley Road, Wayne, N.J. 07470  
TEL: (973) 317-5000, (800) 582-5825 FAX: (973) 317-5030  
Internet Web Site <http://www.jvc.com/pro>  
E-mail: [proinfo@jvc.com](mailto:proinfo@jvc.com)

**JVC CANADA INC.**  
21 Finchdene Square, Scarborough, Ontario M1X 1A7  
TEL: (416) 293-1311 FAX: (416) 293-8208  
Internet Web Site <http://www.jvc.ca/en/pro/>

Printed in Japan

ICN-XXXX

"JVC" is the trademark or registered trademark of Victor Company of Japan, Limited.